

Access E and V 220V

May be ordered as a complete unit, or case now/screen and roller assembly later.

INSTRUCTIONS INSTALLATION & OPERATION

Overview - Components

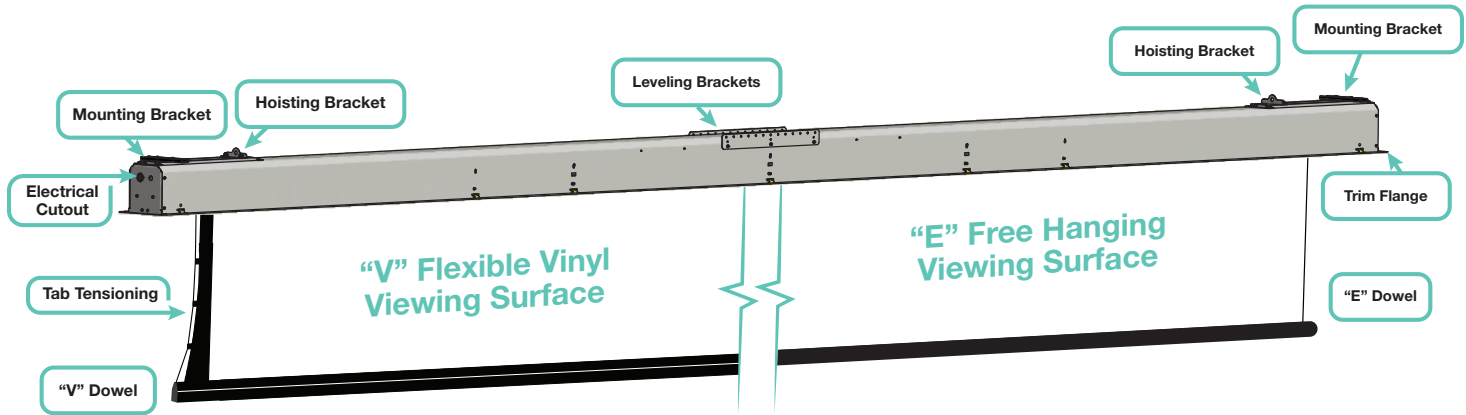

Shipping Brackets Attached to Dowel and Screen Case

(V Screens Only)

Please Note: Shipping brackets must remain in place until product has been mounted and connected to power (see Sections 1 and 4 in this document.).

Also, DO NOT operate screen before removing shipping brackets from screen case.

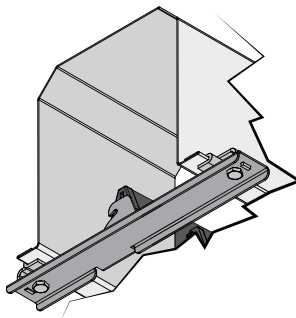

TOOLS REQUIRED



PENCIL



POWER DRILL

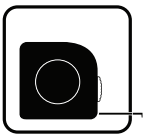

TAPE MEASURE



HARDWARE (by others)

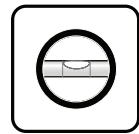

LEVEL

⚠ CAUTION ⚠

Read and understand all warnings (Page 2) before beginning installation.

Contents

Overview - Components.....1	Section 6 - Operation.....5
Section 1 - Removing Shipping Brackets (Tab-Tensioned, "V" Surfaces only).....2	Section 7 - Tab-Tension Adjustment Procedure5
PLEASE READ - Safety Information.....2	Section 8 - Limit Adjustments.....6
Section 2 - Hanging Screen.....3	Section 9 - Case Length Dimensions.....7
Section 3 - Bottom Access Panel Installation/Removal.....3	Section 10 - Case Width Dimensions.....7
Section 4 - Motorized Roller/Fabric Installation.....4	Section 11 - Mounting Bracket Dimensions.....7
Section 5 - Motorized Roller/Fabric Removal.....4	Section 12 - Wiring Diagrams: 220V Motor and Quiet Motor8

If you have any difficulties installing or servicing your Access screen, call your dealer or Draper, Inc.

Section 1 - Removing Shipping Brackets (Tab-Tensioned, "V" Surfaces only)

CAUTION: DO NOT remove shipping brackets until product has been mounted and connected to power (see Section 4 in this document.). Also, DO NOT OPERATE SCREEN BEFORE REMOVING SHIPPING BRACKETS FROM SCREEN CASE.

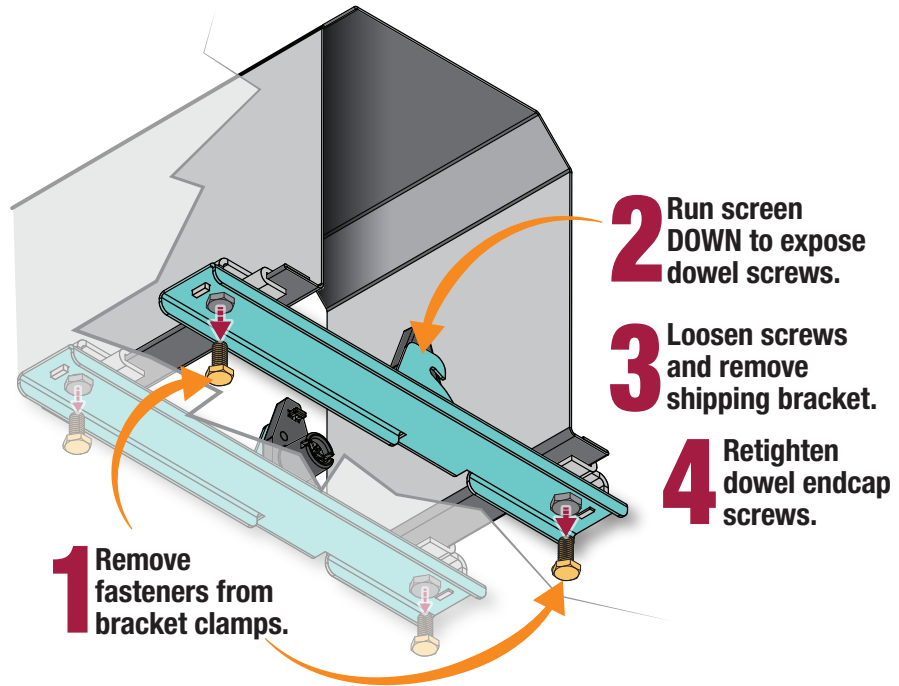

PLEASE READ - Safety Information

Important Safety Information



Important Safety Information

Improper installation and use of Access screen can result in serious injury or death. Primarily, injuries can occur if the unit falls due to imprecise installation, mishandling of the unit during installation, or installation on an insufficient wall or ceiling structure. Please use extreme care.

1. Please read the following installation guidelines thoroughly and follow them carefully. Failure to do so may cause product to fall or otherwise fail, and could result in serious injury.
2. Installation and calibration of the unit should only be performed by an authorized, qualified, and experienced professional. In particular, electrical work and wiring [indicated in diagram by dashed lines] must be completed only by a qualified professional electrician who has read this manual completely and is familiar with the construction and operation of this equipment and the hazards involved.
3. Do not affix the unit to walls or ceilings that have inadequate strength to permanently hold the unit during use. It is the owner's and installer's responsibility to confirm the wall or ceiling to which the unit attaches is sufficient to permanently hold the weight and stress loads of the unit at all times. Draper, Inc., is not responsible for improper installation, application, testing, or workmanship related to the product at place of installation.
4. It is the installer's responsibility to make sure appropriate fasteners are used for mounting.
5. All hardware must be installed level. Unit must be level and square.
6. Never leave the area while operating the unit during installation, maintenance, or normal operation, unless it is secure and safe.
7. Before testing or operation, carefully inspect the entire area and path (especially underneath) of unit to be sure no persons or objects are in the area.
8. Turn off power and any nearby equipment or cables carrying electricity before connecting switches, wires, controls, or electrical components.
9. Do not wire motors in parallel without written permission from Draper, Inc.
10. During testing or operation, carefully watch the surrounding area for any potential safety concerns including nearby persons or objects.
11. After installation, the entire system, including all sensors, should be carefully tested to ensure safe and normal operation. Extreme care should be taken during testing to remain clear of moving parts to avoid possible injury.
12. Operation of unit should be performed only by authorized and qualified personnel, who have been trained in its safe and effective operation and understand its safety features.
13. The safety features of the unit should never be disabled, bypassed, or overridden. The system should not be operated until all safety features are properly and completely installed, calibrated, and tested.
14. Unit may need to comply with local, state, or district rules and regulations, in particular when installed in schools. All applicable rules and regulations should be reviewed before installation and use.
15. **Failure to precisely follow installation guidelines invalidates all warranties.**
16. Custom products/installations may not be reflected in this manual. Call Draper, Inc., if you have questions about the installation of custom products or any questions about your installation.

Before Beginning Installation

1. Look for any job site conditions that could interfere with installation or operation of the system.
2. Read carefully and be sure to understand all installation instructions and all related operations manuals. These instructions are intended to serve as a guide for the installer and owner. They should be followed closely and combined with the expertise of experienced qualified installers. Draper, Inc., is not responsible for improper installation, application, testing, or workmanship related to the product at place of installation. Please retain all instructions for future use.
3. Open cartons lengthwise.
4. Locate and lay out all pieces.
5. Inspect all boxes to make sure you have received the proper unit and parts. Controls may be shipped separately, or in same carton as unit.
6. If you have any difficulties with installing, servicing, or operating your unit, call your dealer or Draper, Inc., 765-987-7999.

Section 2 - Hanging Screen

Please Note: When locating viewing surface and checking clearance for screen operation, ensure that surface is centered in the case.

1. Engage each case mounting bracket (attached to case) with top of housing (Fig. 2) and tighten set screws.
2. Screen should be sufficiently supported to withstand vibration.

Please Note: A hoisting bracket is included on each end of the case to aid in overhead installation.

3. Ensure that fasteners are of adequate strength and suitable for the mounting surface chosen. Supporting hardware such as chains, cables, two 3/8" (9.5 mm) rods, etc., must be precisely vertical.
4. Entire bottom of case must be readily accessible after installation is complete.
5. Front, back, and top of case must be straight—not forced to warp or bow.

CAUTION: Screen case and flange are not designed to serve as ceiling support.

6. Do not seal unit in ceiling until electrical connections have been made and screen operates successfully.

Please Note: If case is painted on location, removal of roller/fabric assembly is recommended prior to painting. If not removed, slot on bottom of case should be shielded to protect viewing surface from paint splatters/overspray.

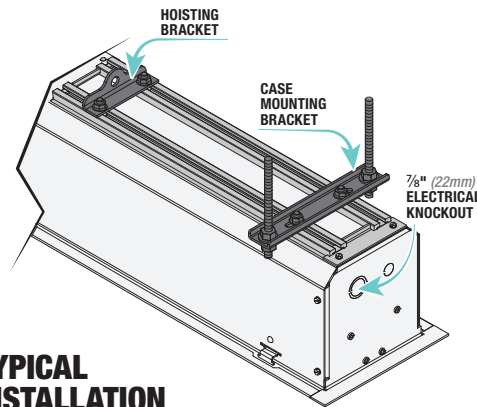

TYPICAL INSTALLATION

With typical installation, brackets may be angled to meet installation requirements.

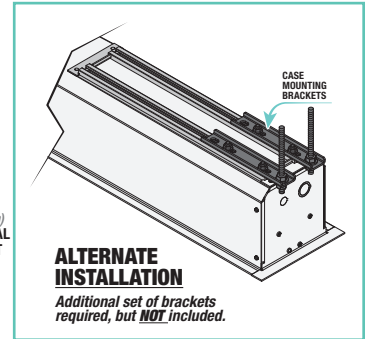

ALTERNATE INSTALLATION

Additional set of brackets required, but NOT included.

Figure 2

Installation of Case

Section 3 - Bottom Access Panel Installation/Removal

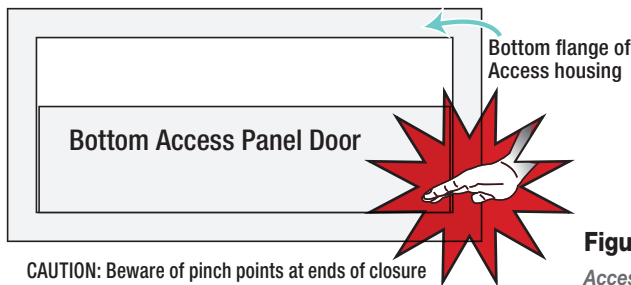

Bottom access panel secures to the screen housing with two screws (one on each end), and held in the closed position by engagement brackets with ball detents that snap into case support brackets (Fig. 3).

Figure 3

Access case as seen from below

CAUTION: For larger sizes, the following requires two people to perform safely.

1. Press up on access panel and pull toward the front of the screen housing to disengage hinges and remove access panel.

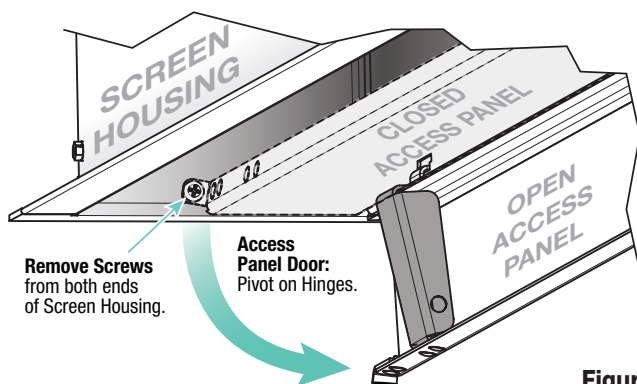
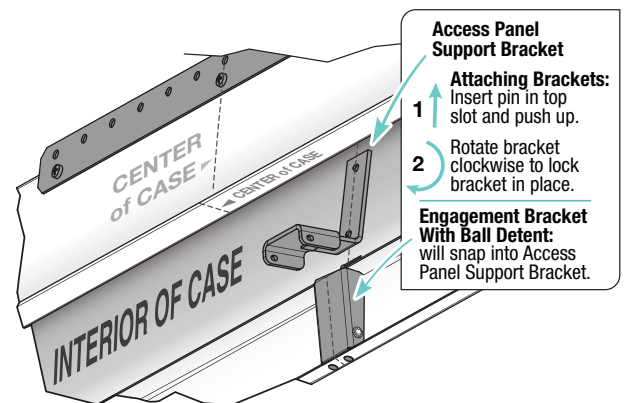

Figure 4

Removing Access Panel

2. To Remove/Install support brackets:



Access Panel Support Bracket

Attaching Brackets:

1. Insert pin in top slot and push up.
2. Rotate bracket clockwise to lock bracket in place.

Engagement Bracket With Ball Detent: will snap into Access Panel Support Bracket.

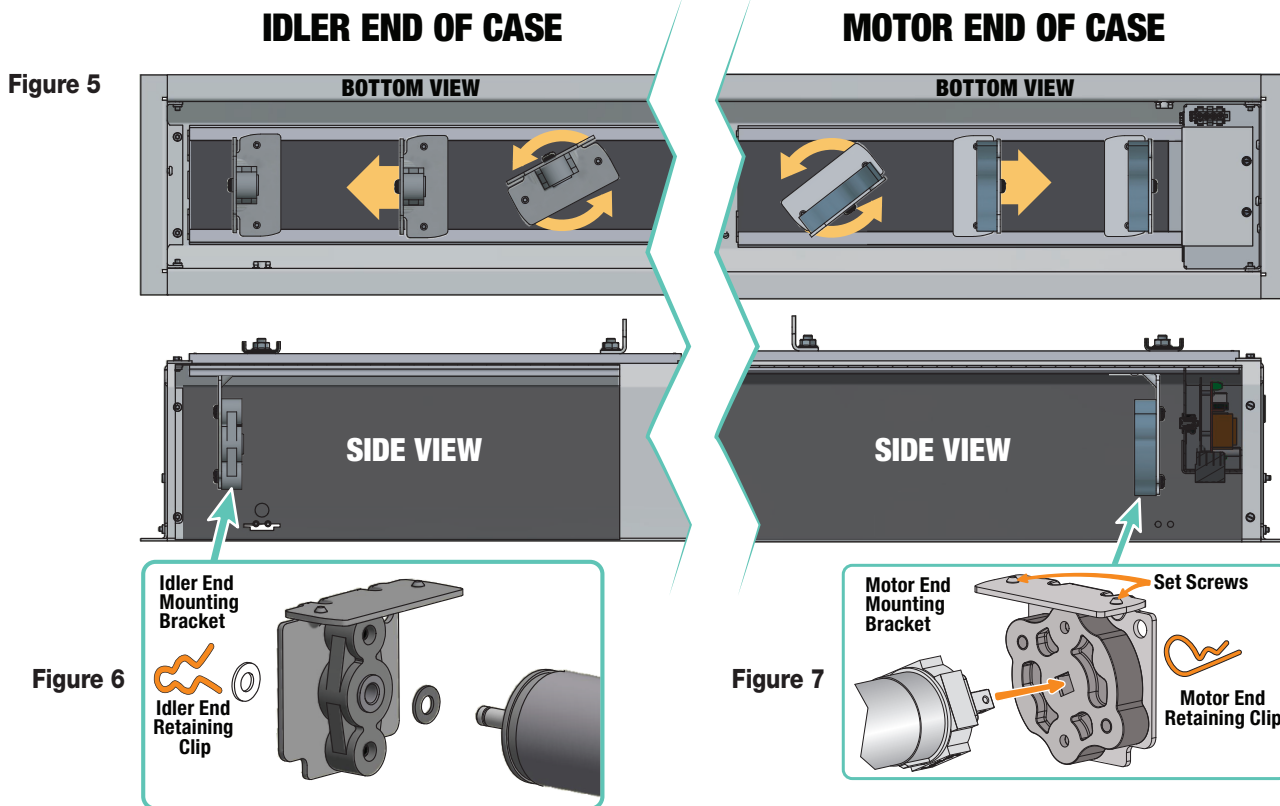

Section 4 - Motorized Roller/Fabric Installation

1. Remove bottom access panel (See Section 3).
2. Back out set screws from top side of motor mounting brackets (See Fig 5).
3. To engage motor end bracket (above the two channels in the top of the screen housing), rotate bracket approximately 45° counterclockwise to allow top surface of motor bracket to rest flat against top inside housing.
4. Rotate bracket clockwise until it engages in channel.
5. Engage idler end bracket in same manner as motor end bracket and slide toward opposite end of screen housing.

⚠ Caution: Step 6 requires two people to perform safely.

6. Locate retaining clips attached to instruction sheet. Lift roller/fabric assembly into screen housing and engage motor head completely into motor bracket, making sure limit switch adjusting knobs are visible from bottom of screen housing (Fig. 7).

Please Note: If snap ring is provided, make sure it engages with motor. If retaining clip is provided instead, install to lock motor end in place.

7. Support idler end of roller and slide mounting bracket toward roller. Insert roller pin into nylon bushing on idler bracket (Fig. 6).
8. Roller idler pin goes through idler bracket. Reinstall washer and retaining clip.

⚠ Caution: Failure to replace washer and retaining clip could result in separation of roller from brackets.

9. Center roller/fabric assembly by sliding mounting brackets left or right.
10. Securely tighten set screws on roller mounting brackets.
11. Connect electrical plug from motor to mating socket on junction box.
12. Attach door support brackets.
13. Reinstall bottom access panel as previously described.

Section 5 - Motorized Roller/Fabric Removal

Reverse the previous instructions ("Motorized Roller/Fabric Installation") for removal of unit.

Section 6 - Operation

CAUTION: When operating for the first time, cycle unit down and up several times to confirm satisfactory operation. Be prepared to cut POWER if necessary.

- **220V SINGLE STATION CONTROL** - 3-position UP-OFF-DOWN switch permits operation to be stopped at any point. Factory adjusted limit switches automatically stop screen when fully down or fully up.
- **24V CONTROL** - 3-button UP-STOP-DOWN switches stop at any point desired and operate in any sequence. Factory adjusted limit switches automatically stop screen when fully up or fully down. Installer should incorporate an all-pole disconnect in fixed wiring available with RF or IR remote.
- **KEY OPERATED SWITCHING** - Two key-operated switches optionally available with this unit:
 - Key-operated power supply switch controls power to screen and switches. When "off", switches will not operate screen. Key may be removed from switch in either "on" or "off" position.
 - Three-position key switch permits the screen to be operated directly by key. Requires screen operator to have a key.
- **RS232 / ETHERNET** - Serial communication and network communication optionally available.

Section 7 - Tab-Tension Adjustment Procedure

Please Note: Draper's Tab-Tensioning System is factory-set, and under normal circumstances will not require field adjustment. If wrinkles are observed, however, follow the adjustment procedure shown in Figure 8.

Figure 8

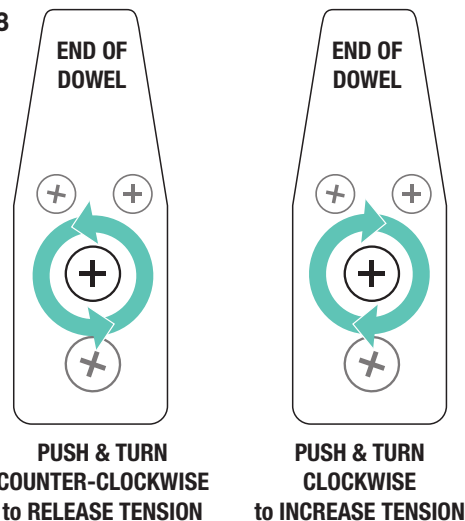

Section 8 - Limit Adjustments

Figure 9

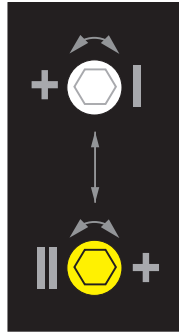

DOWN Limit (I):
Clockwise decreases **down** travel.

UP Limit (II):
Counterclockwise increases **up** travel.

Please Note: Screen limits are factory set. Instructions below for minor adjustments only. Please check with Draper prior to resetting screen limits.

Please Note: If Access screen is "Right Hand Motor" or "Waterfall," the WHITE/DOWN (I) and YELLOW/UP (II) limit screws are reversed (Fig. 10).

Section 8.1 - Standard Motors Limit Adjustments (Fig. 9)

Section 8.1.1 - "Down" Limit Adjustment (requires 5/32" (4 mm) Allen wrench)

To Reduce Screen Drop:

1. Raise screen surface approximately 1' (30 cm) above desired setting and turn off.
2. Turn DOWN (I) limit screw clockwise (3 screw turns = 1/2 roller revolution).
3. Test by lowering screen. Repeat steps 1 & 2 until desired position is reached.

To Increase Screen Drop:

1. Lower screen to down limit.
2. With down switch on, turn DOWN (I) limit screw counterclockwise (3 screw turns = 1/2 roller revolution) to increase drop.
3. Test by raising screen approximately 1' (30 cm) then down to new down limit.
4. Repeat steps 2 and 3 until desired position reached.

Please Note: For Quiet Motor with alternate limit screws: WHITE screw = UP and RED screw = DOWN. However, limits are reversed if surface is waterfall rolled (Fig. 10).

CAUTION:

- Be sure all switches are in "off" position before adjusting limit switches.
- Be prepared to shut off manually while testing.
- Screen may be damaged by lowering it too far and exposing roller.
- Motor must be installed so that limit switches are pointed down.

Figure 10

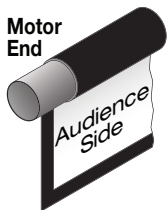

Standard Roll

Left hand motor:
White Socket—Down
Yellow Socket—Up
Right hand motor:
White Socket—Up
Yellow Socket—Down

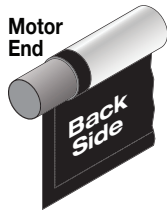

Reverse Roll

Left hand motor:
White Socket—Down
Yellow Socket—Up
Right hand motor:
White Socket—Up
Yellow Socket—Down

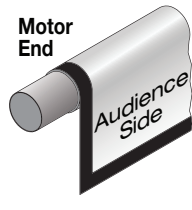

Waterfall Roll

Left hand motor:
White Socket—Up
Yellow Socket—Down
Right hand motor:
White Socket—Down
Yellow Socket—Up

Section 8.1.2 - "Up" Limit Adjustment

If Screen Raises Too High:

1. Lower screen surface approx. 1' (30 cm) below desired setting and turn off.
2. Turn UP (II) limit screw clockwise (3 screw turns = 1/2 roller revolution).
3. Test by advancing screen up.
4. Repeat steps 1 through 3 until desired position is reached.

If Screen Needs to Raise Higher:

1. Lower screen surface approx. 1' (30 cm) below desired setting and turn off.
2. With UP switch on, turn UP (II) limit screw counterclockwise (3 screw turns = 1/2 roller revolution).
3. Repeat steps 1 and 2 until desired position is reached.

CAUTION: DO NOT allow dowel to wrap over roller when operating screen! This could damage screen.

Section 8.2 - ILT Motors with Internal Low-Voltage Control Limit Adjustments (Fig. 11)

Please Note: Hold STOP button for 3-5 seconds while in programming mode to reverse motor direction.

Please Note: When ordering a motor with internal low-voltage controller, if case ships separate from "guts," it includes 25' (7.6 m) cable and special low-voltage switch.

Figure 11

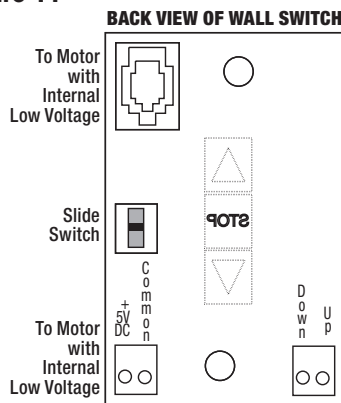

POSITION	FUNCTION
DOWN	Set LOWER limit
UP	Set UPPER limit
CENTER	Normal Operation

1. Connect ILT switch to motor via terminal blocks, or via modular port using a four conductor modular cable. When using modular cable, cable connectors MUST NOT be crimped in reverse, as with standard telephone cable. (For Dry Contacts Wiring Diagram, see Section 12.)
2. Set slide switch to lower position. Hold DOWN button to move viewing surface to desired lower limit. If screen moves in opposite direction, release DOWN button and hold STOP button for 4 seconds. This reverses operation of UP and DOWN switches.
3. Move slide switch into center position. Wait several seconds.

Please Note: Do Not move slide switch from DOWN to UP in one motion. This will set limits in same position.

4. Set slide switch to higher position. Move viewing surface to desired upper limit by holding UP button on wall switch.
5. Return slide switch to center position to resume normal operation.

Please Note: Press and release UP button on switch to move screen to upper limit. Press and release DOWN button to move screen to lower limit.

- While motor is in motion, press STOP button for less than 2 seconds to stop viewing surface at present position.
- Once motor is stopped, press STOP button to move viewing surface to alternate format position.
- Hold STOP button, when motor is at rest or in motion, for 3-5 seconds to record new alternate format position.
- Hold STOP button for 3-5 seconds while in programming mode to reverse motor direction.

Please Note: 5V DC must be connected to be able to set limits using the wall switch.

Section 9 - Case Length Dimensions

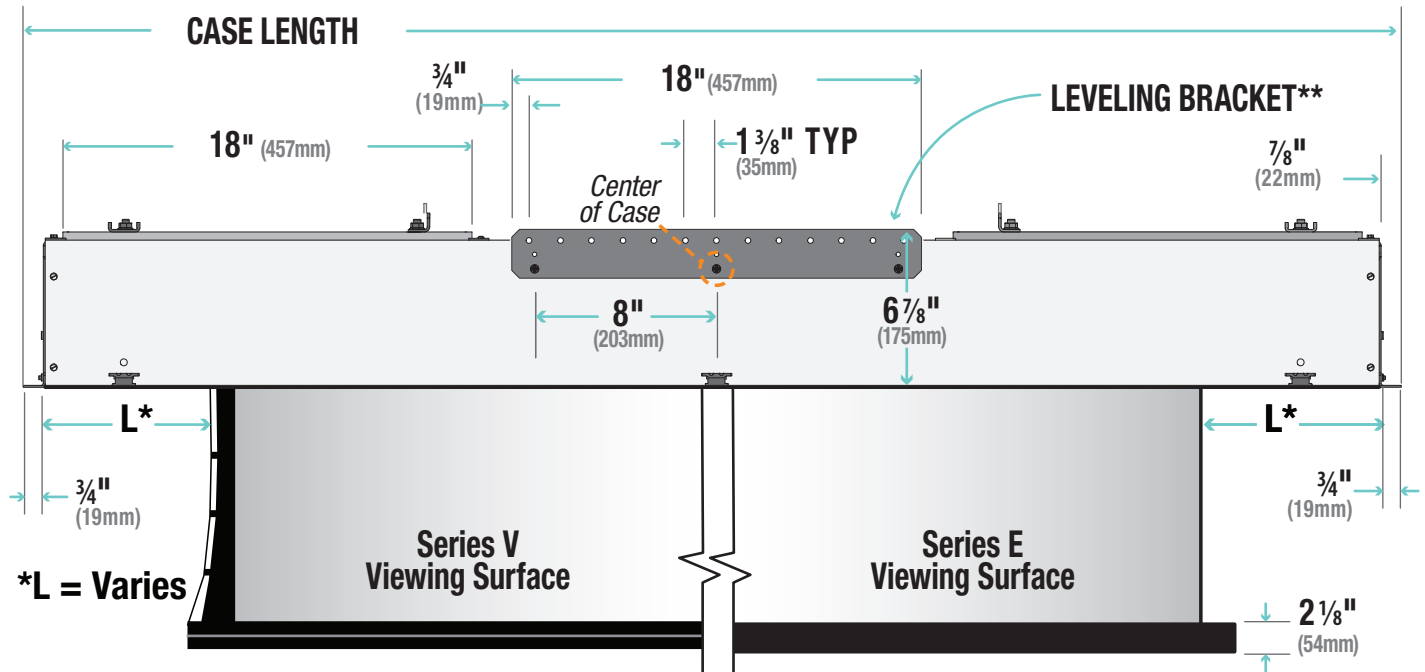

- For minimum length of ceiling cutout: subtract 1 1/4" (32mm) from case length (measured from outer edge of flanges).
- For minimum width of cutout (front to back): see case width dimensions below.
- **Leveling bracket is used to level the case and should NOT be used to support the weight of the unit.
- The leveling bracket is screwed to the side of the case and remains stationary. Hardware used for leveling provided by others.
- There are several knock-outs in the screen housing to allow the Leveling Bracket to be adjusted laterally up to 16" (40.6cm) in either direction.

Section 10 - Case Width Dimensions

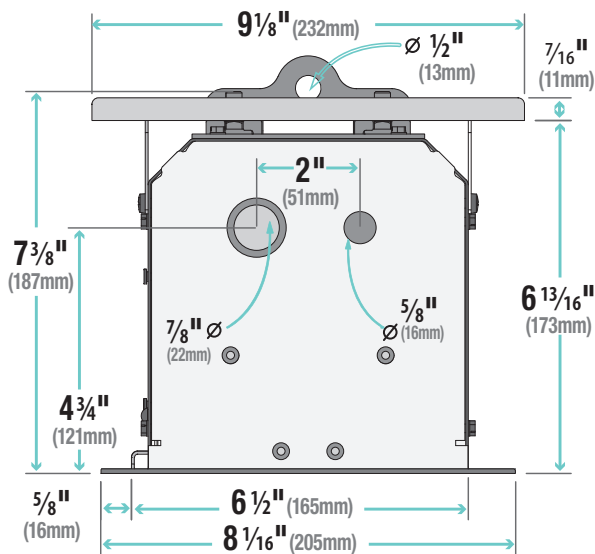

Standard Motor Wiring is on the AUDIENCE LEFT END of Screen Case.

Section 11 - Mounting Bracket Dimensions

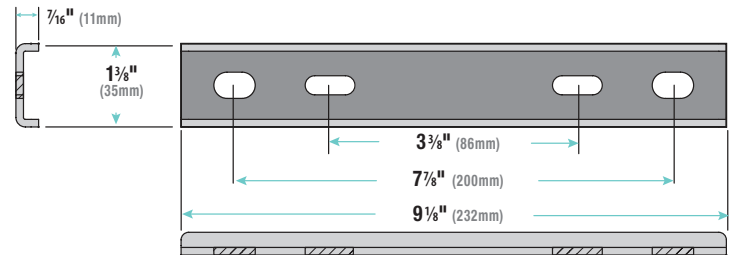

Section 12 - Wiring Diagrams: 220V Motor and Quiet Motor

Please Note: Do not wire motors in parallel.

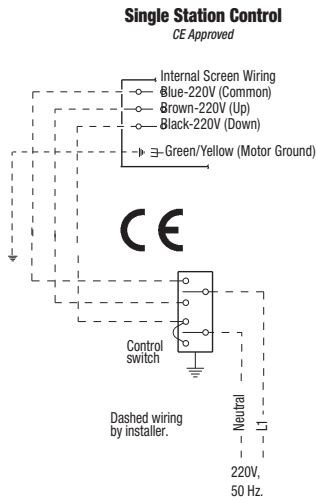

220V Motor and Quiet Motor with Internal Low-Voltage Controller

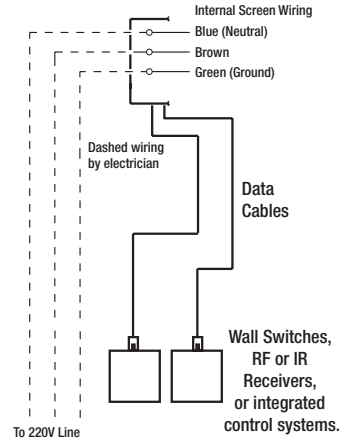

* These wiring diagrams are for Access screens with motor on audience left (standard), and fabric unrolling from the back of the roller (standard).

Connecting Switch to ILT Motor

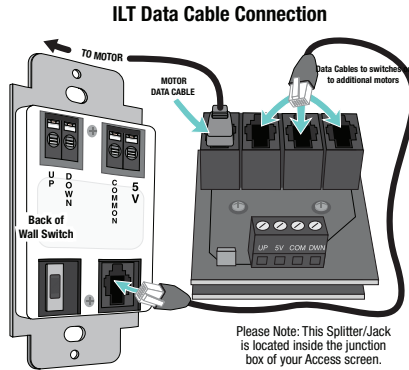

OR

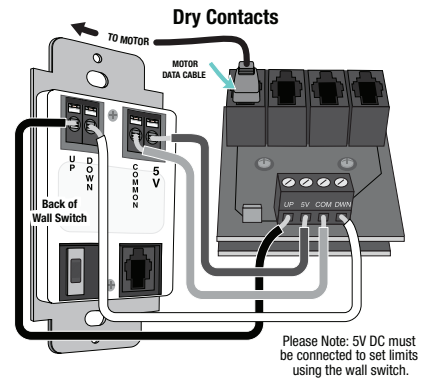

Internal LVC-IV - Single or Multiple Projection Screen Wiring Diagram

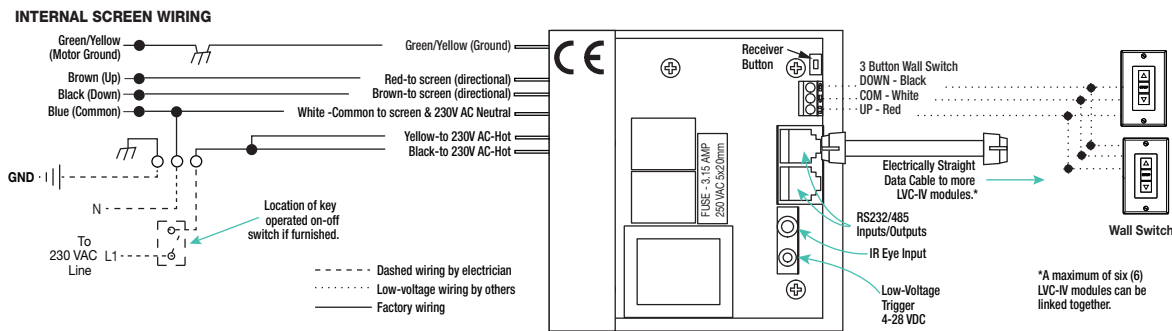

External LVC-IV - Single or Multiple Projection Screen Wiring Diagram

